

Sampling System for Pressure Lines according to VDI 2083/7 Standard

SYS 525



Sampling system for pressure lines SYS 525

The sampling system SYS 525 is used for purity control of ultra-pure gas supply systems and complies with the VDI 2083/7 standard in all its structural design requirements.

The device allows a pressure decoupling and thus the sampling of a substantial primary sample from which the particle counter then takes its sample for analysis. Isoaxial and isokinetic sampling is ensured by an electronic flow monitoring of the primary volume flow and the structural design of the SYS 525 with an internal device sampling probe for the particle counter.

The sampling system SYS 525 also ensures safe acceptance testing of pressure gas lines in the case if there is no special isoaxial sampling port on the ultra-pure gas supply system.

The sampling system is designed to be used for particle counters with a sample flow rate of 28.3 l/min (1 cfm). These measuring devices detect particles down to 0.1 μm , thus allowing the safe testing of gases in the required purity classes.

Special Advantages

- Allows for particle measurement in pressure gas lines with conventional measurement technology
- Electronically monitored isokinetic sampling
- Suitable for air, nitrogen and gases with similar physical characteristics

Applications

- Acceptance and monitoring of pressure systems for pure gases in accordance with VDI 2083/7 standard
- Process control in the chemical industry, pharmaceutical manufacturing, food industry ...
- Aerosol research

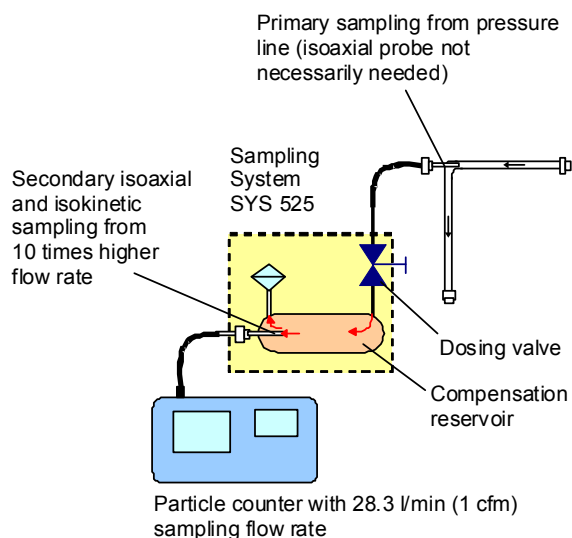

Setup of the Sampling System SYS 525



Specifications

Operating Principle

By means of a throttle valve, the user adjusts the total volume flow taken from the pressure system of 40 l/min. A volume flow measurement downstream of the valve indicates to the user whether or not this volume flow is realized, or in which direction the throttle valve has to be turned for correction. Before the excess gas is vented through an absolute filter inside the device, an isoaxial, isokinetic sampling is done by the particle counter with its respective volume flow. Arrangement and cross section of the sampling probe are so designed that the isokinetic sampling is ensured within specified limits.

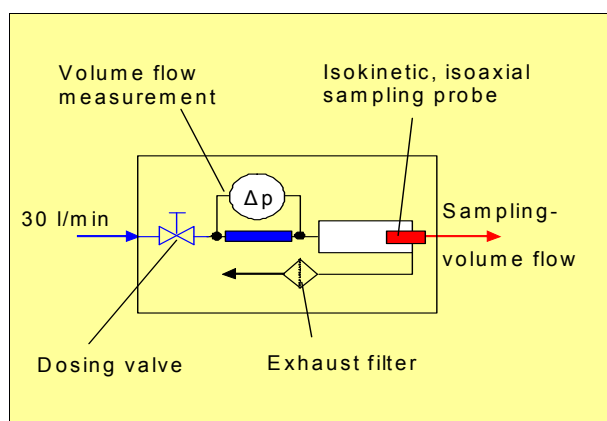

Functional principle of the Sampling System SYS 525

Technical Data

Inlet pressure	max. 8 bar min. 1 bar
Primary sample flow	40 l/min
Secondary sample flow	28.3 l/min
Approved gases	Ambient air, nitrogen
Tolerance for isokinetic sampling	± 7 %
Power supply	12 V DC (via mains adapter)
Dimensions (W x H x D)	270 x 200 x 150 mm
Weight	1.5 kg

QMS certified to
DIN EN ISO 9001.



12 100 11908 TMS

For more information please visit
our website at
www.topas-gmbh.de

Specifications are subject to
change without notice.

© Copyright 2015 Topas GmbH.



Topas GmbH
Technologie-orientierte
Partikel-, Analysen- und Sensortechnik
Oskar Röder Str. 12 · D-01237 Dresden

Phone +49 (351) 21 66 43 - 0
Fax +49 (351) 21 66 43 55
E-mail office@topas-gmbh.de
Internet www.topas-gmbh.de

TOPAS-GMBH DE

PARTICLE UNDER CONTROL