

Aerosol Distribution and Dilution System

ADD 536



Aerosol Distribution and Dilution System ADD 536

Hospital operating rooms are specially designed to avoid contaminations and therefore additional infections of patients during operations. To assure a low level of particle contaminations a laminar air flow is applied to the operating table. To verify the retention efficiency of this flow regime a verification with a defined test aerosol is required according to the standards DIN 1946-4 and SWKI 99-3. For that reason a total particle rate of $6.3 \cdot 10^9$ P/min has to be distributed to six different positions and emitted with a reliable long term stability. From the standards it is also required that this total particle rate is continuously monitored and controlled by a particle counter. The Topas Aerosol Distribution and Dilution system ADD 536 meets all these required demands for providing a defined test aerosol with the following features:

- Internal generation of a total nominal flow (free of particles) for supplying the six aerosol ejectors
- Homogeneous mixing of the test aerosol coming from an external aerosol generator with this total transportation flow
- Internal adjustable aerosol dilution ratio for direct connection of a particle counter used for controlling a stable particle rate
- Uniform aerosol distribution to six aerosol ejectors

Special Advantages

- Designed to comply with the requirements of the German standard DIN 1946-4 and the Swiss guideline SWKI 99-3
- Reliable particle generation rate with an excellent long term stability (particles/time)
- Status information on dilution ratio and total flow rate integrated at the front

Applications

- Protection grade measurement of operating rooms/theatres according to German DIN 1946-4 and Swiss SWKI 99-3 and VDI 2167 Part 1
- Generation of test aerosols by providing a reliable, reproducible, long term constant, but concentration variable particle stream in connection with a high-concentration particle source e.g. for verification or calibration of particle counters (dilution series with PSL aerosols)

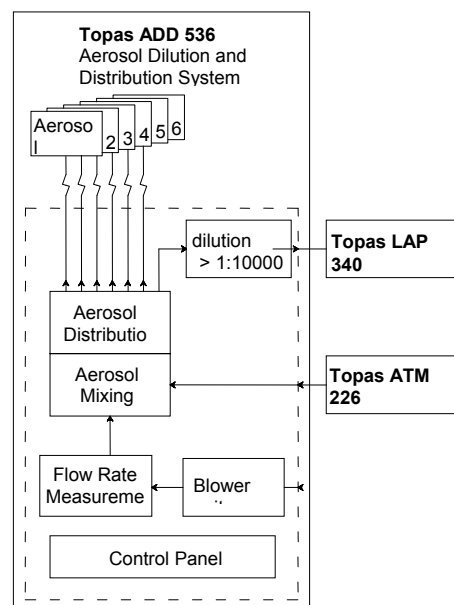

Setup of the ADD 536



Specifications

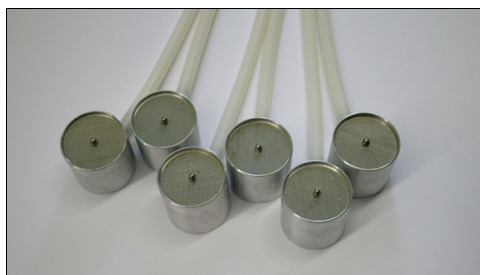

Aerosol-Ejectors



Aerosol Generator ATM 226



Partikelzähler LAP 340

Details

- By an external particle counter continuously controlled particle production rate
- Compact portable design, easy to setup
- Internal generation of particle free transportation flow without requesting a compressed air source
- Integrated, highly efficient aerosol dilution, with a wide range of adjustable dilution ratios with excellent reproducibility to be directly connected to particle counter
- Electronically controlled and adjusted dilution ratio adapted to particle counter in use

Necessary Accessories

- Optical Particle Counter (flow rate: 0.1...1 cfm, lower detection limit $>0.3 \mu\text{m}$, e.g. *Topas LAP 340, Lighthouse Solair*)
- Aerosol Generator, (flow rate $<300 \text{ l/h}$, particle rate $>6.3 \cdot 10^9 \text{ P/min}$, particle output adjustable, e.g. *Topas ATM 226*)

Complementary Accessories

- Software package *CREWin* for automated data acquisition and printout protocol as result according to current standards or guidelines of protection grade measurements
- Software package *PASWin* for automated data acquisition and device control of optical particle counters

Technical Data

Dilution Ratio	Adjustable to the used particle counter, $> 1:10000$
Flow Rate of the Particle Counter	2.83 l/min (0.1 cfm) ... 28.3 l/min (1 cfm)
Flow Rate of the Aerosol Generator	max. 5 l/min
Internal additional carrier airstream	100 l/min
Aerosol Ejectors	6 pieces, diameter 65 mm
Power Supply	230 V AC
Dimensions	250 x 340 x 330 mm
Hose Connector	10 mm
Weight	8.5 kg
Dilution Ratio	Adjustable to the used particle counter, $> 1:10000$
Flow Rate of the Particle Counter	2.83 l/min (0.1 cfm) ... 28.3 l/min (1 cfm)

QMS certified to
DIN EN ISO 9001.



12 100 11908 TMS

For more information please visit our website at www.topas-gmbh.de

Specifications are subject to change without notice.

© Copyright 2015 Topas GmbH.

