

## Aerosol Distribution and Dilution System

## ADD 536



Aerosol Distribution and Dilution System ADD 536

Hospital operating rooms are specially designed to avoid contaminations and therefore additional infections of patients during operations. To assure a low level of particle contaminations a laminar air flow is applied to the operating table. To verify the retention efficiency of this flow regime a verification with a defined test aerosol is required according to the standards DIN 1946-4 and SWKI 99-3. For that reason a total particle rate of  $6.3 \cdot 10^9$  P/min has to be distributed to six different positions and emitted with a reliable long term stability. From the standards it is also required that this total particle rate is continuously monitored and controlled by a particle counter. The Topas Aerosol Distribution and Dilution system ADD 536 meets all these required demands for providing a defined test aerosol with the following features:

- Internal generation of a total nominal flow (free of particles) for supplying the six aerosol ejectors
- Homogeneous mixing of the test aerosol coming from an external aerosol generator with this total transportation flow
- Internal adjustable aerosol dilution ratio for direct connection of a particle counter used for controlling a stable particle rate
- Uniform aerosol distribution to six aerosol ejectors

### Special Advantages

- Designed to comply with the requirements of the German standard DIN 1946-4 and the Swiss guideline SWKI 99-3
- Reliable particle generation rate with an excellent long term stability (particles/time)
- Status information on dilution ratio and total flow rate integrated at the front

### Applications

- Protection grade measurement of operating rooms/theatres according to German DIN 1946-4 and Swiss SWKI 99-3 and VDI 2167 Part 1
- Generation of test aerosols by providing a reliable, reproducible, long term constant, but concentration variable particle stream in connection with a high-concentration particle source e.g. for verification or calibration of particle counters (dilution series with PSL aerosols)

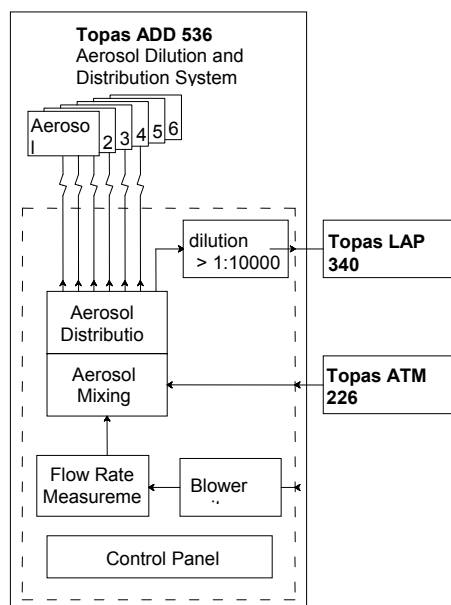

Setup of the ADD 536



## Specifications



Aerosol-Ejectors



Aerosol Generator ATM 226



Partikelzähler LAP 340

### Details

- By an external particle counter continuously controlled particle production rate
- Compact portable design, easy to setup
- Internal generation of particle free transportation flow without requesting a compressed air source
- Integrated, highly efficient aerosol dilution, with a wide range of adjustable dilution ratios with excellent reproducibility to be directly connected to particle counter
- Electronically controlled and adjusted dilution ratio adapted to particle counter in use

### Necessary Accessories

- Optical Particle Counter (flow rate: 0.1...1 cfm, lower detection limit >0.3 µm, e.g. *Topas LAP 340, Lighthouse Solair*)
- Aerosol Generator, (flow rate <300 l/h, particle rate >6.3·10<sup>9</sup> P/min, particle output adjustable, e.g. *Topas ATM 226*)

### Complementary Accessories

- Software package *CREWin* for automated data acquisition and printout protocol as result according to current standards or guidelines of protection grade measurements
- Software package *PASWin* for automated data acquisition and device control of optical particle counters

### Technical Data

Dilution Ratio	Adjustable to the used particle counter, > 1:10000
Flow Rate of the Particle Counter	2.83 l/min (0.1 cfm) ... 28.3 l/min (1 cfm)
Flow Rate of the Aerosol Generator	max. 5 l/min
Internal additional carrier airstream	100 l/min
Aerosol Ejectors	6 pieces, diameter 65 mm
Power Supply	230 V AC
Dimensions	250 x 340 x 330 mm
Hose Connector	10 mm
Weight	8.5 kg
Dilution Ratio	Adjustable to the used particle counter, > 1:10000
Flow Rate of the Particle Counter	2.83 l/min (0.1 cfm) ... 28.3 l/min (1 cfm)

QMS certified to  
DIN EN ISO 9001.



12 100 11908 TMS

For more information please visit our website at [www.topas-gmbh.de](http://www.topas-gmbh.de)

Specifications are subject to change without notice.

© Copyright 2015 Topas GmbH.

