

Pore Size Meter for Filter Papers, Non-Woven, Woven Materials and other Porous Materials

PSM 165



Pore Size Meter PSM 165

The unique Pore Size Meter PSM 165 provides pore size information for a wide range of porous materials with applications in the field of filtration, hygiene and Tissue engineering. Materials that may be tested include filter papers, micro sieves, non-woven as well as woven materials and sintered polymers or metals.

The operator is guided through the test procedure by an easy to use software package PSMWin running on a standard PC.

The following parameters describing the inner structure of the material can be obtained with this compact measuring instrument:

Bubble Point	Pressure drop at which the wetted sample starts to become gas permeable.
Pore Size Distribution	Permeability weighted pore size distribution calculated from wet flow curve (pressure drop vs. volumetric flow rate of the wet sample) and dry flow curve (similar to wet flow, but obtained on a dry sample).
Mean Flow Pore Size	Pore size diameter corresponding to the pressure drop where the wet flow value is half (50%) of the dry flow.

Special Advantages

- Uncomplicated sample change
- Flow rate range adjusts to test item
- Computer controlled test procedure and user friendly data acquisition and presentation in Windows environment
- User defined test fluid

Applications

- Filter material development
- Quality assurance
- Specification of filter materials

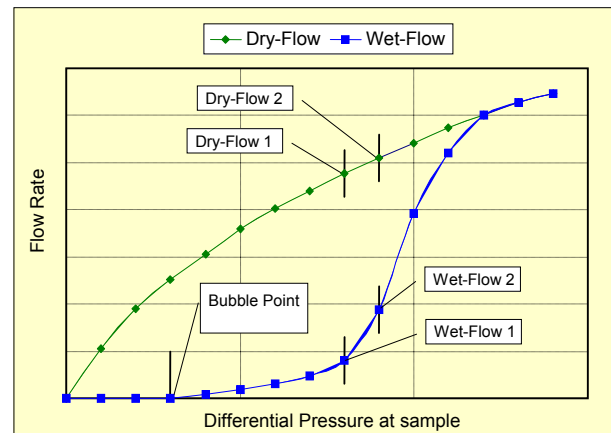

Measured pressure drop vs. flowrate for a dry and wetted sample of non-woven material

The pressure drop across the filter media sample is measured as a function of the gas flow rate through the sample for the dry and the wetted sample material.

As a test fluid Topor (perfluoro compound, Topas specific testing fluid) is recommended due to its excellent wetting behavior. Data acquisition and processing is completely computerized guiding the operator with specific instructions.



Principle of Operation

Principle of Operation

The basic principle of pore size measurements is that liquid filled pores will become gas permeable at a certain gas flow pressure. This initial pressure indicates the bubble point of a material.

As real materials contain a range of pore sizes, the bubble point corresponds to the opening pressure of the largest pore. The measured pressure value is dependent on the surface tension of the test fluid used.

By further increasing the gas flow rate, and therefore the pressure drop across the material under test, it is possible to calculate a pore size distribution from these two measured parameters.

The applied measuring principle is in close accordance with ASTM E 1294-89 and ASTM F 316-03 standards. In addition to Topor, measurements can be carried out with a range of other test fluids. To achieve reliable results the surface tension of the test fluid must be known and a sufficient wetting of the test sample has to be guaranteed.

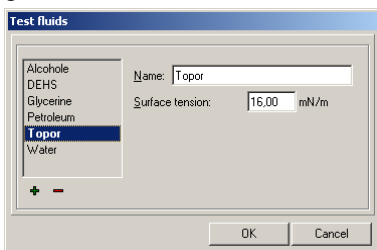

Dialog window for choosing a test fluid

Flow Scheme of PSM 165

The basic configuration of the device is shown in the following figure. Two high-precision mass flow controllers are used to generate a defined flowrate which is passed through the test sample. The resulting differential pressure is measured by pressure sensors which can be customized to provide the best possible result for a specific sample type.

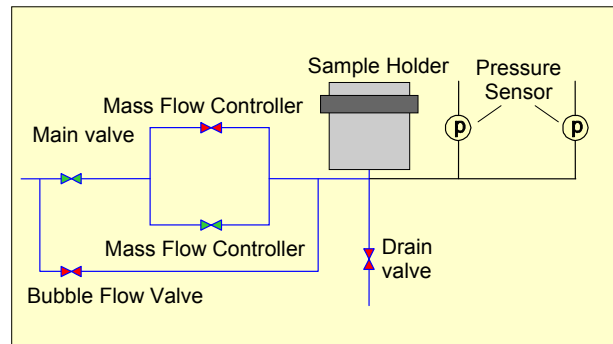

Basic setup of the PSM 165

Test Procedure

- Connect the instrument to compressed air supply and PC (RS 232 interface)
- Prepare the sample and insert into the holder
- Run PSMWin software which guides the operator through all necessary steps of a complete sample test
- Create new test file in software and select desired test conditions
- Start measurement
- Test duration depends on sample (approx. 15 min)
- Display measuring data as graphics or table and store/print/transfer data

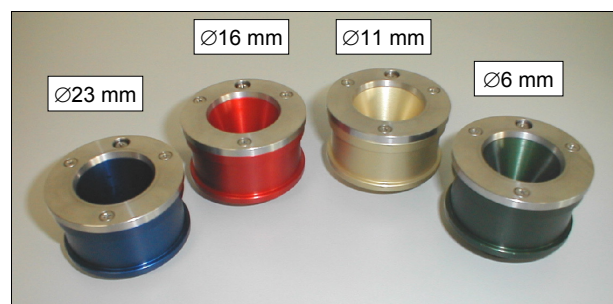

Colour-coded adapters for clamping the sample



Software PSMWin

The specially developed data acquisition and control software PSMWin runs on all Windows-platforms, is easy to use, and features some of the following functions:

- Guiding the operator through the whole test procedure
- Automated test procedure
- Data presentation with protocol printout
- Dynamic data exchange with Excel and via "copy and paste" for other applications
- Pore size calculator

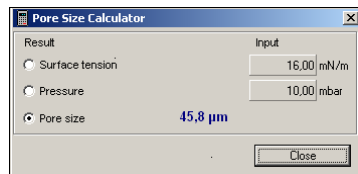
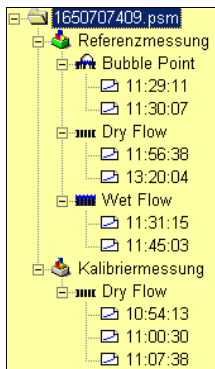

Pore size calculator for evaluation of the measuring range

Test file structure

As the test procedure is fully automated, the operator must only perform the sample preparation. The measurement itself is done automatically recording pressure drop and flow rate data during the test. Necessary adjustments of test parameters to different sample properties can be done easily via the software.

The measuring range of the PSM 165 depends on the specified pressure transducers and the test fluid used for the wet flow measurement. For a fast evaluation of measurable pore sizes there is a pore size calculator implemented in the software.

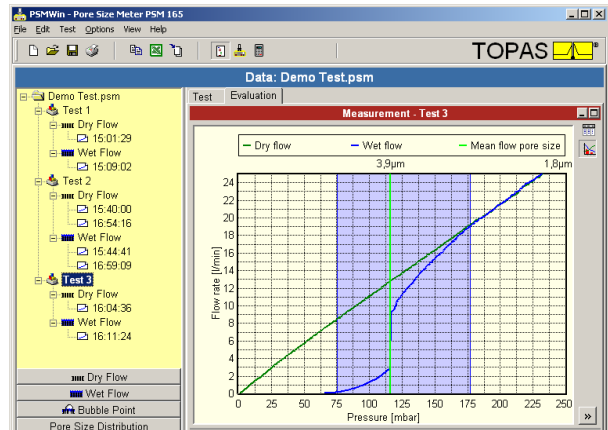

Measuring data window with a dry flow curve (green) and a wet flow curve (blue); light blue colored background: analyzed pressure range

The figure above shows an example of flow curves generated during a measurement. The dry flow curve (green) shows a typical continuous increase of the pressure drop across the sample as flow rate increases. The wet flow curve (blue) starts to increase at the initial bubble point pressure and converges to the dry flow curve at increased flow rates.

A new test file with detailed sample information and test data is easily created by completing the dialog form before starting a measurement.

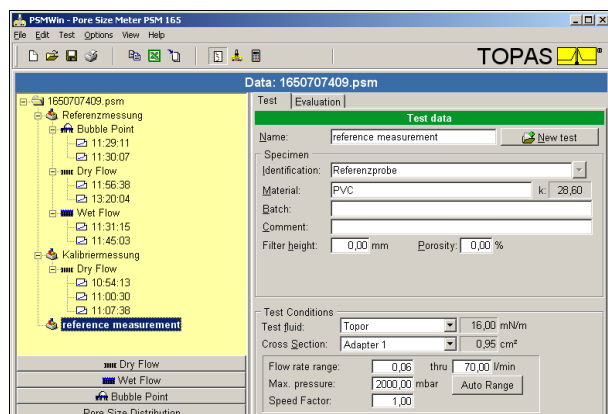

Input dialog for sample data and test conditions



Specifications

Measurement results may be presented in customized reports using PSMWin software. In addition, results can be exported to MS-office applications (Excel) and printed out as a clearly arranged measurement report.

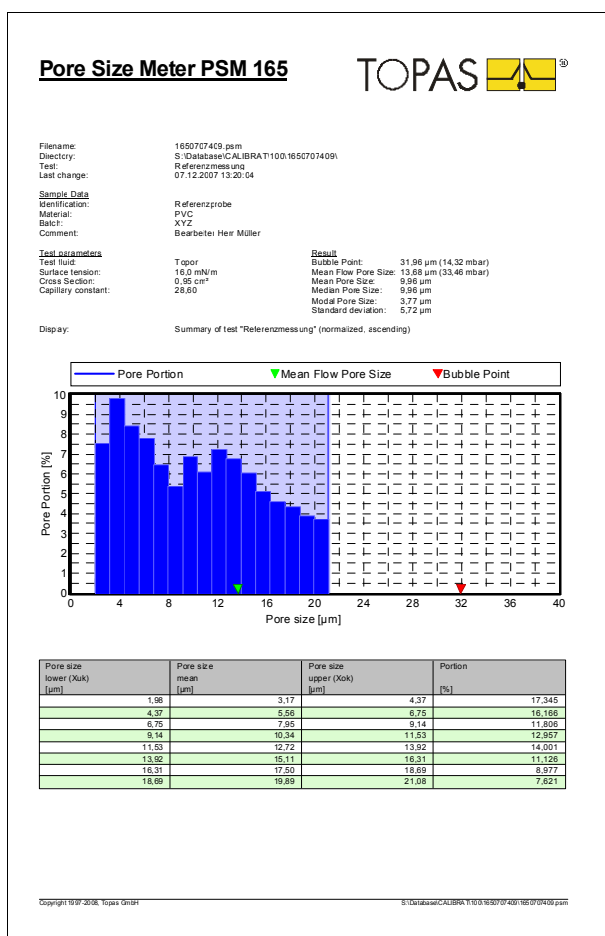

Technical Data

Measuring range:

PSM 165/U
(3.5-1000 mbar)

0.5...130 µm (Topor)
2.1...250 µm (Water)

PSM 165/L
(0.2-350 mbar)

1.3...250 µm (Topor)
5.9...250 µm (Water)

PSM 165/H
(3.5-2000 mbar)

0.3...130 µm (Topor)
1.0...250 µm (Water)

Sample adapters

6 mm, 11 mm, 16 mm,
23 mm (exchangeable)*

Sample dimensions

Diameter: 30...40 mm
Sample thickness:
0...15 mm

Flow rate

3.6 l/h...4200 l/h*

Type

Desktop device with
standard RS 232
interface and Windows
data acquisition as well
as control software
PSMWin

Compressed air supply

4 bar; 5 Nm³/h

Power supply

110...230 V AC

Size

480 x 390 x 310 mm

Weight

12 kg

^{*)} other customized adapters on demand

QMS certified to DIN EN
ISO 9001



12 100 11908 TMS

For more information please visit
our website at
www.topas-gmbh.de

Specifications are subject to
change without notice.

© Copyright 2015 Topas GmbH.



Topas GmbH
Technologie-orientierte
Partikel-, Analysen- und Sensortechnik
Oskar Röder Str. 12 · D-01237 Dresden

Telefon +49 (351) 21 66 43 - 0
Fax +49 (351) 21 66 43 55
E-Mail office@topas-gmbh.de
Internet www.topas-gmbh.de

TOPAS-GMBH DE

PARTICLE UNDER CONTROL